

FIRE PUMPS



GENERAL PUMPS

ESPAÑA



LISTED
EX26841



APPROVED



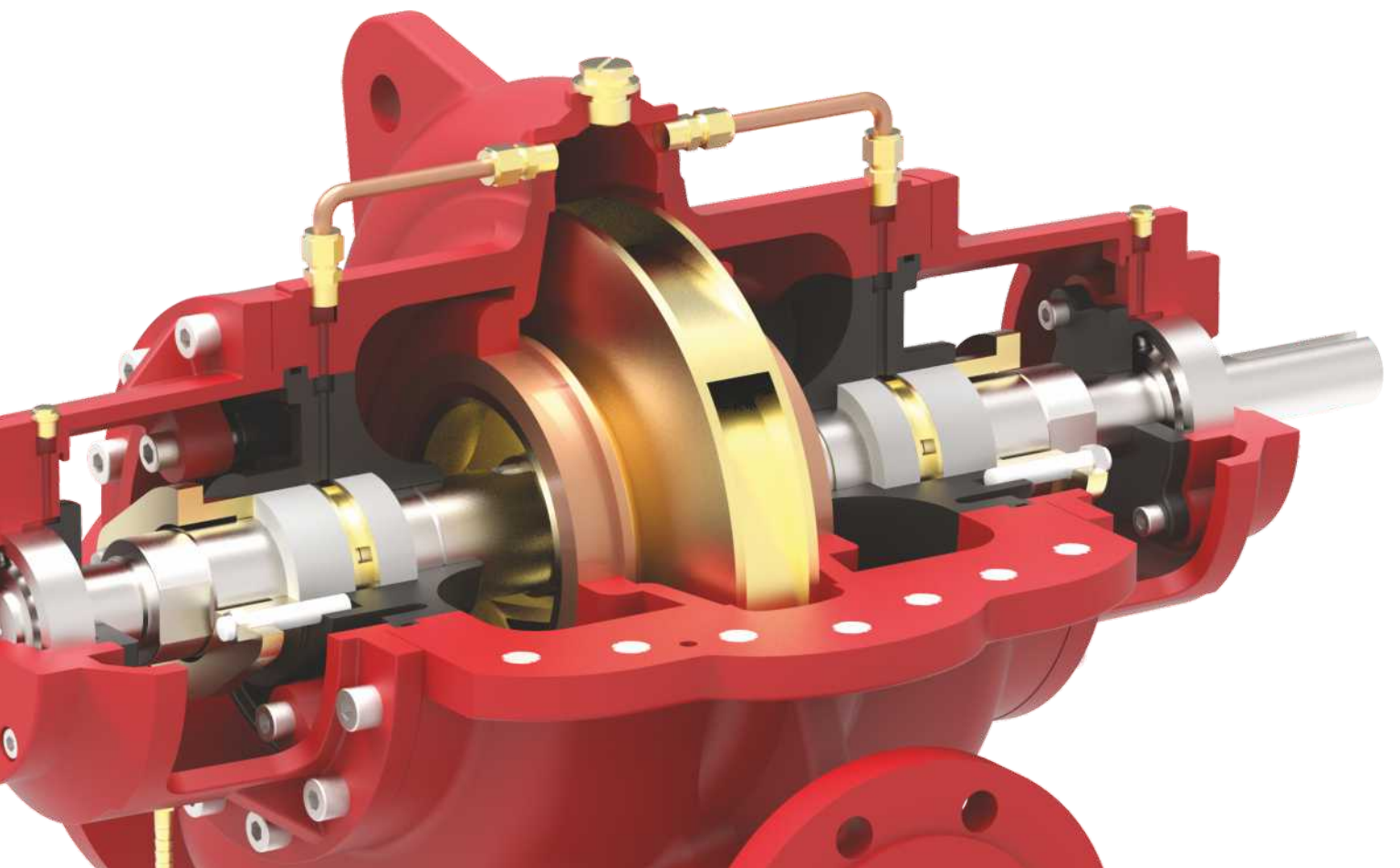



GENERAL PUMPS

ESPAÑA

General Pumps S.L.U., was established more than 25 years ago in Valencia, Spain.

We are a major manufacturer in Spain of a wide variety of water pumps for various applications. We have two factories in Spain with the total space of more than 2600 Sq. M.

Today we have one of the most comprehensive ranges of pumps for Fire, HVAC, Water Treatment and Plumbing Industry. The product line ranges from small domestic pumps to large Industrial application pumps. The pumps can be offered in various Metallurgies such as Cast Iron, Stainless Steel, Bronze, etc.

We have our product distribution channels in North and South America, Europe, Middle East and Far East. More than 75% of our sales revenue is generated through exports across the world.

We have a comprehensive range of Fire Pumps which are UL Listed and FM Approved.

The Quality Management System at our manufacturing facility is certified to the latest International Standard of ISO 9001.

We believe in providing our customers with a complete solution for all their Fire Pumping needs. Our Engineers can assist you in making the right choice of product for your Fire Pumping



End Suction Fire Pumps

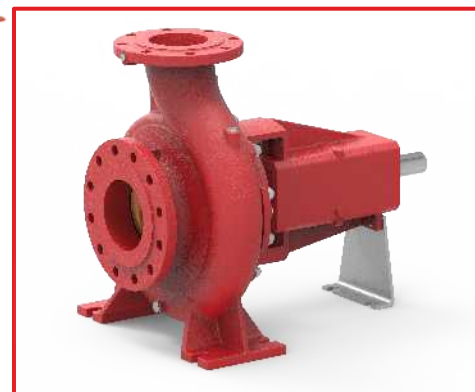
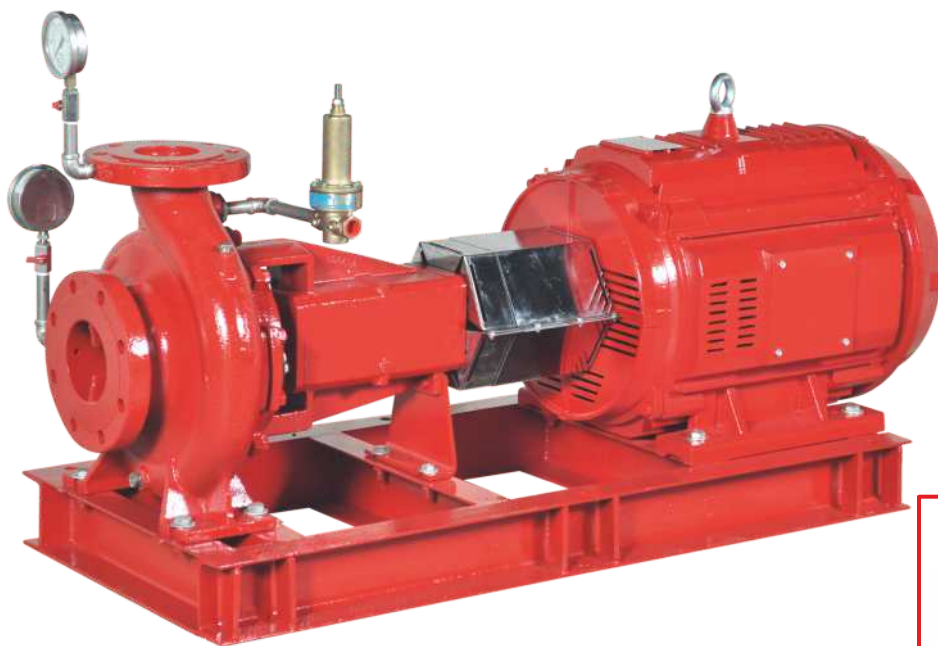

Introduction

General Pumps offers FGBS series state-of-the-art fire pumps with diesel engine or electric motor driven, single-stage End-Suction pump.

These pumps are typically used in fire-fighting applications for supplying water to fire hose reels, fire hydrants or sprinkler systems.

Pumps have a discharge range from 50 to 1000 USgpm and the head range from 3.72 to 9.9 bar.

These fire pumps meet or exceed the requirements of NFPA20.

Installations of these pumps would ensure the safety of human life, buildings, and expensive equipments and plants. FGBS fire pumpset shall be used only where a positive suction is provided as specified in NFPA20.

These fire pumps typically consists of the following equipments:

- Single-Stage End-Suction pump
- Electric motor or Diesel Engine
- Cooling system for Diesel Engine
- Fuel system for Diesel Engine
- Battery for Diesel Engine electric start
- Exhaust system for Diesel Engine
- Diesel Engine / Electric Motor Fire pump controller
- Suction and Discharge pressure gauges
- Casing Relief Valve for Motor Fire pump
- Base frame

All above equipments except fuel supply tank and fire pump controller are mounted on a common base frame.

General Pumps can also supply packaged fire pumping system with all required accessories ready for site installation.

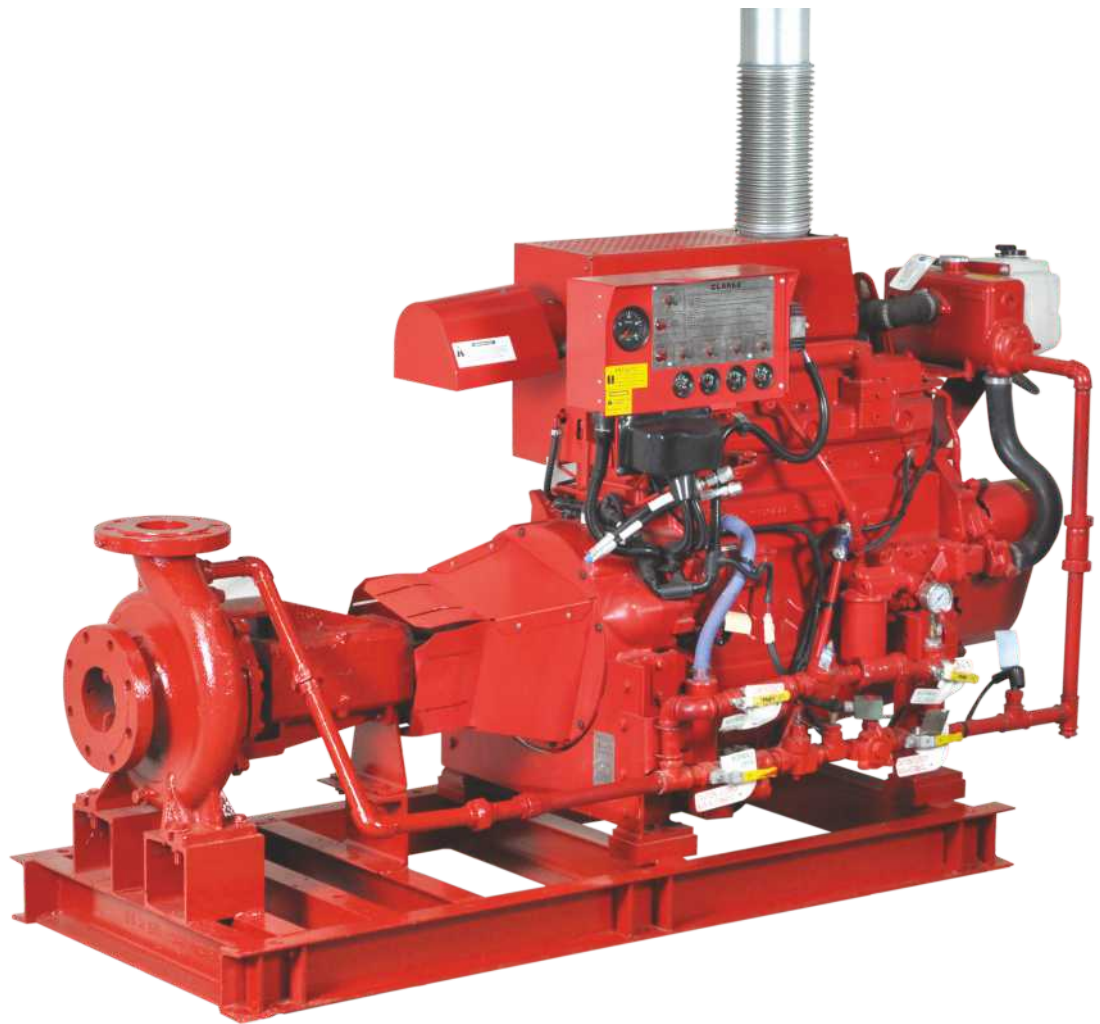

Applications

The FGBS fire pumpsets are used in small capacity, diesel engine or motor driven fire-fighting applications for supplying water to fire hose reels, fire hydrants or sprinkler systems in areas which are prone to the hazards of fire.

The typical applications are as follow:

- Commercial complexes & high rise buildings
- Petrochemical industries and Gas plants
- Airports and ports
- Jetties
- Marine applications
- Power stations and transformer stations
- Chemical industries
- Manufacturing plants
- Fire-work industries
- Warehouses / godowns

Features & benefits

FGBS fire pumpset offers all the features & benefits as mentioned in our GBS standard pump series data booklet. Following are the additional features & benefits offered by these pumpsets:

- State-of-the-art design fire pumping system.
- NFPA-20 design
- Compact diesel engine driven pump package
- Rugged construction
- More economical than Horizontal Split Case diesel fire pump packages
- Back pull-out design which simplifies inspection and maintenance without disturbing pipe work
- The pump impellers are dynamically balanced to grade 6.3 of ISO 1940-1
- Efficient operation
- Lower initial cost
- Reduced installation time and cost
- Easy access to all working parts
- Ease of maintenance
- Single source unit responsibility.

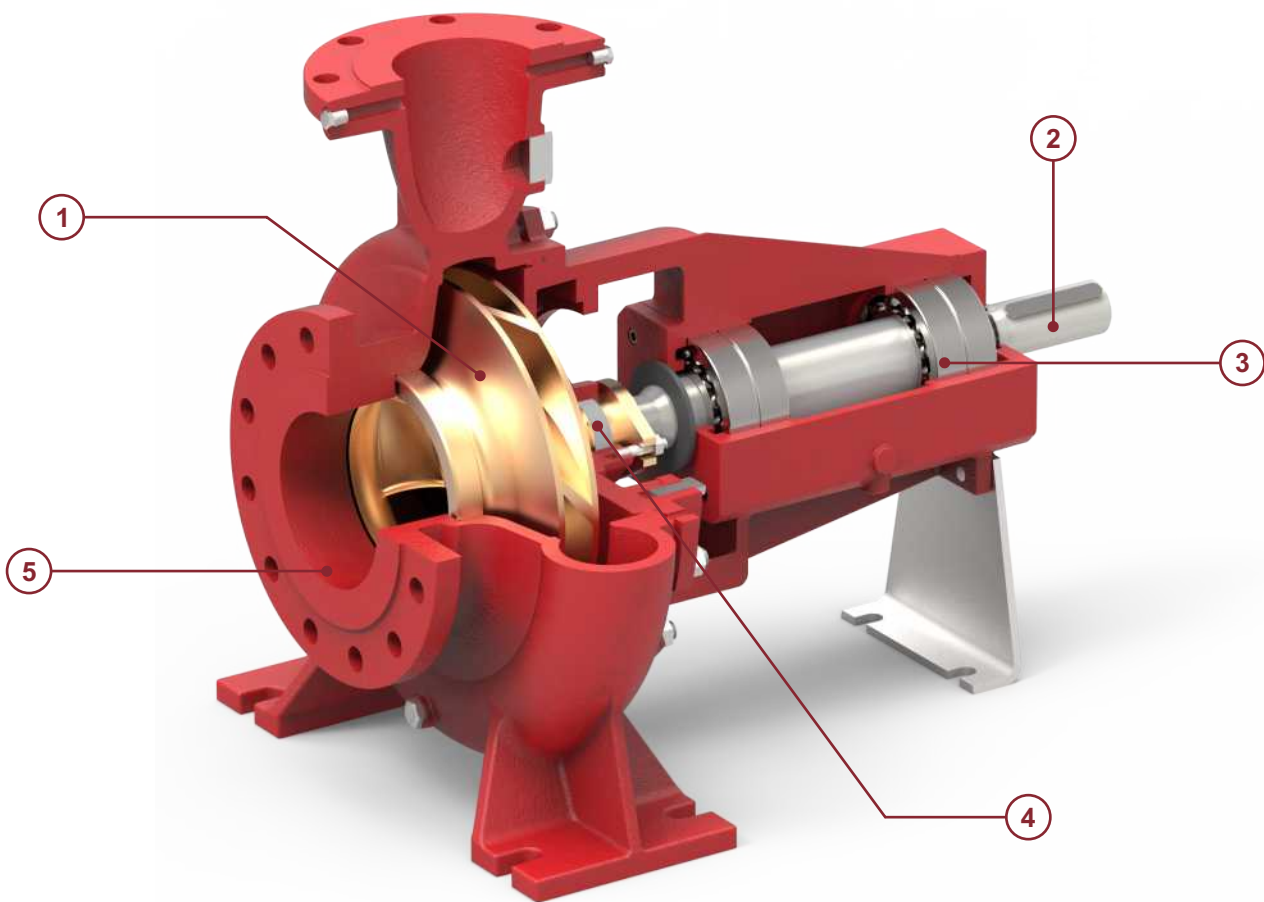

1 - Impeller & Casing

- Impeller is dynamically balanced to grade G6.3 balance quality in accordance to ISO 1940-1.
- Impeller & Casing are designed using state of art CFD tools to ensure optimal performance.

2 - Shaft

- Heavy duty stainless steel shaft completely sealed and dry for zero corrosion.
- Short and rigid with negligible vibrations.
- Replaceable shaft protecting sleeves.
- No threads exposed to pump medium, long operating life and no corrosion.
- Adjustment-free assembly.

3 - Bearing

- Heavy duty and permanently grease lubricated antifriction bearings for long service life.
- Open gland, enough space for service activities.

4 - Seal

- Asbestos - free, soft packed stuffing boxes.

5 - Casing

- End Suction backpullout design permits maintenance of the pump without removing the pipes.
- Rugged Ball Bearings on Drive as well as Non Drive end.
- Flange drilled as per ASME B16.42 class 300.
- Smooth surface inside & CED coated for superior corrosion protection.
- Replaceable wear ring protect the casing and the impeller running clearances.
- Heavy duty casing design for high working pressure.

Dimensions

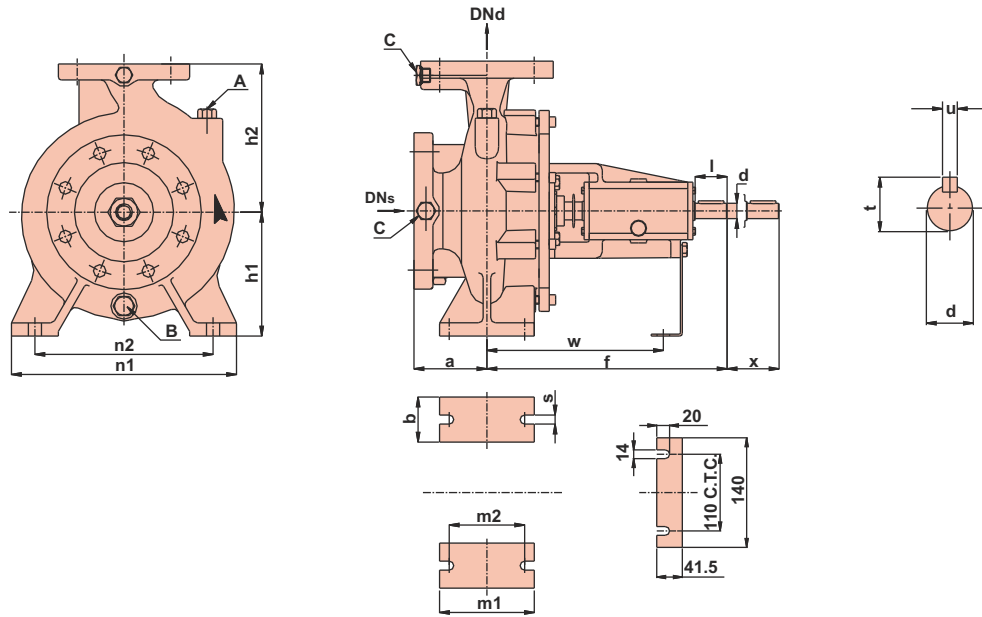

Model	DN _s	DN _d	a	b	d.k6	f	h1	h2	l	m1	m2	n1	n2	s	t	u	w	x	A	B	C
FGBS 65-40-250	65	40	100	65	24	360	180	225	50	125	95	320	250	14	27	8	260	100	Ø3/8"	Ø1/2"	Ø1/4"
FGBS 80-65-250	80	65	100	80	42	482	200	250	80	160	120	360	280	18	45	12	340	140	Ø3/8"	Ø1/2"	Ø1/4"
FGBS 125-100-250	125	100	140	80	42	527	225	280	110	160	120	400	315	18	45	12	360	140	Ø3/8"	Ø1/2"	Ø1/4"
FGBS 125-100-315	125	100	140	80	48	630	250	315	110	160	120	400	315	18	51.5	14	445	140	Ø3/8"	Ø1/2"	Ø1/4"
FGBS 150-125-315	150	125	140	100	48	640	280	355	110	200	150	500	400	22	51.5	14	455	140	Ø3/8"	Ø1/2"	Ø1/4"

Flange Dimensions

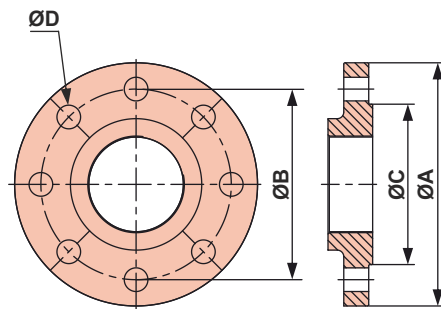

Class 300 Flange Dimensions

Model	Suction				Discharge			
	ØA	ØB	ØC	ØD x Nos. of holes	ØA	ØB	ØC	ØD x Nos. of holes
FGBS 65-40-250	190	149	125	Ø7/8" x 8	155	114	91	Ø7/8" x 4
FGBS 80-65-250	210	168	144	Ø7/8" x 8	190	149	125	Ø7/8" x 8
FGBS 125-100-250	280	235	211	Ø7/8" x 8	255	200	176	Ø7/8" x 8
FGBS 125-100-315	280	235	211	Ø7/8" x 8	255	200	176	Ø7/8" x 8
FGBS 150-125-315	320	270	246	Ø7/8" x 12	280	235	211	Ø7/8" x 8

Approved Fire Pump Models with Rating

RATED CAPACITY- 50 US GPM									
Sr. No.	Pump Model	UL Listed Pressure		FM Approved Pressure		Rated Speed (rpm)	Suction Inlet Dia. (inch)	Discharge Outlet Dia. (inch)	Stage(s)
		(psi)	(bar)	(psi)	(bar)				

1	FGBS 65-40-250	96-130	6.61-8.96	96-130	6.61-8.96	2900	2.5	1.5	1
2	FGBS 80-65-250	85-134	5.86-9.23	85-130	5.86-8.96	2900	3	2.5	1

RATED CAPACITY- 100 US GPM									
Sr. No.	Pump Model	UL Listed Pressure		FM Approved Pressure		Rated Speed (rpm)	Suction Inlet Dia. (inch)	Discharge Outlet Dia. (inch)	Stage(s)
		(psi)	(bar)	(psi)	(bar)				

1	FGBS 65-40-250	95-127	6.55-8.75	96-127	6.61-8.75	2900	2.5	1.5	1
2	FGBS 80-65-250	84-134	5.79-9.23	84-129	5.79-8.89	2900	3	2.5	1

RATED CAPACITY- 150 US GPM									
Sr. No.	Pump Model	UL Listed Pressure		FM Approved Pressure		Rated Speed (rpm)	Suction Inlet Dia. (inch)	Discharge Outlet Dia. (inch)	Stage(s)
		(psi)	(bar)	(psi)	(bar)				

1	FGBS 80-65-250	83-135	5.72-9.30	83-129	5.72-8.89	2900	3	2.5	1
---	-----------------------	--------	-----------	--------	-----------	------	---	-----	---

RATED CAPACITY- 200 US GPM									
Sr. No.	Pump Model	UL Listed Pressure		FM Approved Pressure		Rated Speed (rpm)	Suction Inlet Dia. (inch)	Discharge Outlet Dia. (inch)	Stage(s)
		(psi)	(bar)	(psi)	(bar)				

1	FGBS 80-65-250	81-135	5.58-9.90	81-129	5.58-8.89	2900	3	2.5	1
---	-----------------------	--------	-----------	--------	-----------	------	---	-----	---

RATED CAPACITY- 250 US GPM									
Sr. No.	Pump Model	UL Listed Pressure		FM Approved Pressure		Rated Speed (rpm)	Suction Inlet Dia. (inch)	Discharge Outlet Dia. (inch)	Stage(s)
		(psi)	(bar)	(psi)	(bar)				

1	FGBS 80-65-250	78-134	5.37-9.23	77-129	5.30-8.89	2900	3	2.5	1
---	-----------------------	--------	-----------	--------	-----------	------	---	-----	---

RATED CAPACITY- 300 US GPM									
Sr. No.	Pump Model	UL Listed Pressure		FM Approved Pressure		Rated Speed (rpm)	Suction Inlet Dia. (inch)	Discharge Outlet Dia. (inch)	Stage(s)
		(psi)	(bar)	(psi)	(bar)				

1	FGBS 125-100-250	94-132	6.48-9.10	94-132	6.48-9.10	2900	5	4	1
---	-------------------------	--------	-----------	--------	-----------	------	---	---	---

Approved Fire Pump Models with Rating

RATED CAPACITY- 400 US GPM									
Sr. No.	Pump Model	UL Listed Pressure		FM Approved Pressure		Rated Speed (rpm)	Suction Inlet Dia. (inch)	Discharge Outlet Dia. (inch)	Stage(s)
		(psi)	(bar)	(psi)	(bar)				

1	FGBS 125-100-250	93-131	6.41-9.03	93-131	6.41-9.03	2900	5	4	1
2	FGBS 125-100-315	122-207	8.41-14.27	118-203	8.13-13.99	2900	5	4	1
3	FGBS 150-125-315	111-192	7.65-13.23	107-195	7.37-13.55	2900	6	5	1

RATED CAPACITY- 450 US GPM									
Sr. No.	Pump Model	UL Listed Pressure		FM Approved Pressure		Rated Speed (rpm)	Suction Inlet Dia. (inch)	Discharge Outlet Dia. (inch)	Stage(s)
		(psi)	(bar)	(psi)	(bar)				

1	FGBS 125-100-250	92-131	6.34-9.03	93-131	6.41-9.03	2900	5	4	1
2	FGBS 125-100-315	121-207	8.34-14.27	117-203	8.06-13.99	2900	5	4	1
3	FGBS 150-125-315	110-192	7.58-13.23	107-195	7.37-13.44	2900	6	5	1

RATED CAPACITY- 500 US GPM									
Sr. No.	Pump Model	UL Listed Pressure		FM Approved Pressure		Rated Speed (rpm)	Suction Inlet Dia. (inch)	Discharge Outlet Dia. (inch)	Stage(s)
		(psi)	(bar)	(psi)	(bar)				

1	FGBS 125-100-250	91-130	6.27-8.96	91-130	6.27-8.96	2900	5	4	1
2	FGBS 125-100-315	120-207	8.27-14.27	116-203	7.99-13.99	2900	5	4	1
3	FGBS 150-125-315	110-192	7.58-13.23	106-194	7.30-13.37	2900	6	5	1

RATED CAPACITY- 750 US GPM									
Sr. No.	Pump Model	UL Listed Pressure		FM Approved Pressure		Rated Speed (rpm)	Suction Inlet Dia. (inch)	Discharge Outlet Dia. (inch)	Stage(s)
		(psi)	(bar)	(psi)	(bar)				

1	FGBS 125-100-250	86-125	5.92-8.61	85-125	5.86-8.61	2900	5	4	1
2	FGBS 125-100-315	111-203	7.65-13.99	108-199	7.44-13.72	2900	5	4	1
3	FGBS 150-125-315	109-190	7.51-13.1	104-194	7.17-13.37	2900	6	5	1

RATED CAPACITY- 1000 US GPM									
Sr. No.	Pump Model	UL Listed Pressure		FM Approved Pressure		Rated Speed (rpm)	Suction Inlet Dia. (inch)	Discharge Outlet Dia. (inch)	Stage(s)
		(psi)	(bar)	(psi)	(bar)				

1	FGBS 150-125-315	104-188	7.17-12.96	99-190	6.86-13.1	2900	6	5	1
---	-------------------------	---------	------------	--------	-----------	------	---	---	---

Horizontal Split Case Quick Selection guide

Rated Capacity in GPM / (LPM)	Pressure in PSI(Bar)	Electric & Diesel Engine Pump Model	Rated Pressure in Bar	Jockey Flow in USgpm	Jockey Pump Model	Electric Motor HP @ 2900 RPM	Diesel Engine HP @ 3000 RPM	Jockey Pump HP @ 2900 RPM
400(1514)	245-336 (16.89-23.16)	FGHC 125-100-400 2900/3000 RPM	17	20	GCR10-18	200HP	191HP	10HP
			18	20	GCR10-18	200HP	191HP	10HP
			19	20	GCR 10-20	200HP	217HP	10HP
			20	20	GCR 10-20	200HP	217HP	10HP
			21	20	GCR 10-22	200HP	249HP	10HP
			22	20	GCR 10-22	250HP	249HP	10HP
			23	22.5	GCR15-17	250HP	275HP	20HP
450 (1703)	71-131 (4.89-9)	FGHC 125-100-250 2900/3000 RPM	5	22.5	GCR 4-8	40 HP	45HP	2HP
			6	22.5	GCR 4-10	50 HP	60HP	3HP
			7	22.5	GCR 4-10	60 HP	60HP	3HP
			8	22.5	GCR 4-12	60 HP	71HP	3HP
			9	22.5	GCR 4-14	75 HP	83HP	4HP
450 (1703)	244-335 (16.82-23.09)	FGHC 125-100-400 2900/3000 RPM	17	22.5	GCR 10-18	200HP	191HP	10HP
			18	22.5	GCR 10-20	200HP	217HP	10HP
			19	22.5	GCR 10-20	200HP	217HP	10HP
			20	22.5	GCR 10-22	200HP	249HP	10HP
			21	22.5	GCR 10-22	250HP	249HP	10HP
			22	22	GCR 10-22	250HP	275HP	10HP
500 (1892)	71-131 (4.89-9)	FGHC 125-100-250 2900/3000 RPM	5	25	GCR 4-8	40 HP	45HP	2HP
			6	25	GCR 4-10	50 HP	60HP	3HP
			7	25	GCR 4-12	60 HP	71HP	3HP
			8	25	GCR 4-14	75 HP	83HP	4HP
			9	25	GCR 4-14	75 HP	83HP	4HP
500 (1892)	131-214 (9-14.75)	FGHC 150-125-315 2900/3000 RPM	9	25	GCR 4-14	100 HP	115HP	4HP
			10	22.3	GCR 10-10	125 HP	145HP	5.5HP
			11	25	GCR 10-12	125 HP	145HP	5.5HP
			12	25	GCR 10-14	150 HP	175HP	7.5HP
			13	25	GCR 10-14	150 HP	175HP	7.5HP
			14	22.3	GCR 10-14	200 HP	216HP	7.5HP
			14.75	25	GCR 10-16	200 HP	216HP	7.5HP

Horizontal Split Case Quick Selection guide

Rated Capacity in GPM / (LPM)	Pressure in PSI(Bar)	Electric & Diesel Engine Pump Model	Rated Pressure in Bar	Jockey Flow in USgpm	Jockey Pump Model	Electric Motor HP @ 2900 RPM	Diesel Engine HP @ 3000 RPM	Jockey Pump HP @ 2900 RPM
500 (1893)	243-334 (16.75-23.02)	FGHC 125-100-400 2900/3000 RPM	17	25	GCR10-18	200HP	217HP	10HP
			18	25	GCR 10-20	200HP	217HP	10HP
			19	25	GCR 10-20	200HP	249HP	10HP
			20	25	GCR 10-22	250HP	249HP	10HP
			21	25	GCR 10-22	250HP	249HP	10HP
			22	25	GCR15-17	250HP	275HP	20HP
750(2839)	65-130 (4.4-8.96)	FGHC 125-100-250 2900/3000 RPM	5	37.5	GCR 10-6	50 HP	60HP	3HP
			6	37.5	GCR 10-7	60 HP	71HP	4HP
			7	37.5	GCR 10-8	75 HP	83HP	4HP
			8	37.5	GCR 10-10	100 HP	115HP	5.5HP
			8.96	37.5	GCR 10-12	100 HP	115HP	5.5HP
750(2839)	129-213 (8.8-14.68)	FGHC 150-125-315 2900/3000 RPM	9	37.5	GCR 10-12	125 HP	145HP	5.5HP
			10	37.5	GCR 10-12	125 HP	145HP	5.5HP
			11	37.5	GCR 10-14	150 HP	175HP	7.5HP
			12	37.5	GCR 10-14	200 HP	216HP	7.5HP
			13	37.5	GCR 10-16	200 HP	216HP	7.5HP
			14	37.5	GCR 10-16	200 HP	216HP	7.5HP
			14.68	37.5	GCR 10-18	200 HP	275HP	10 HP
750 (2839)	236-323 (16.27-22.27)	FGHC 125-100-400 2900/3000 RPM	16.5	37.5	GCR 10-20	250HP	249HP	10HP
			17	37.5	GCR 10-20	250HP	249HP	10HP
			18	37.5	GCR10-22	250HP	275HP	10HP
			19	37.5	GCR10-22	250HP	275HP	10HP
			20	37.5	GCR15-17	250HP	300HP	20HP
750 (2839)	141-201 (9.73-13.85)	FGHC 200-150-300 2900/3000 RPM	9.73	37.5	GCR10-12	125HP	145HP	5.5HP
			10	37.5	GCR10-12	125HP	175HP	5.5HP
			11	37.5	GCR10-14	150HP	175HP	7.5HP
			12	37.5	GCR10-14	200HP	193HP	7.5HP
			13	37.5	GCR10-16	200HP	216HP	7.5HP
			13.85	37.5	GCR10-16	200HP	216HP	7.5HP
1000(3785)	80-142 (5.51- 9.7)	FGHC 200-150-250 2900/3000 RPM	6	50	GCR 15-5	100 HP	115HP	5.5 HP
			7	50	GCR 15-6	125 HP	145HP	7.5 HP
			8	50	GCR 15-7	150 HP	175HP	7.5 HP

Horizontal Split Case Quick Selection guide

Rated Capacity in GPM / (LPM)	Pressure in PSI(Bar)	Electric & Diesel Engine Pump Model	Rated Pressure in Bar	Jockey Flow in USgpm	Jockey Pump Model	Electric Motor HP @ 2900 RPM	Diesel Engine HP @ 3000 RPM	Jockey Pump HP @ 2900 RPM
1000(3785)	127-210 (8.75-14.4)	FGHC 150-125-315 2900/3000 RPM	9	50	GCR 15-8	150 HP	175HP	10 HP
			10	50	GCR 15-8	150 HP	175HP	10 HP
			11	50	GCR 15-9	200 HP	216HP	10 HP
			12	50	GCR 15-10	200 HP	216HP	15 HP
			13	50	GCR 15-12	200 HP	275HP	15 HP
			14	50	GCR 15-12	250 HP	275HP	15 HP
1000(3785)	141-201 (9.73-13.85)	FGHC 200-150-300 2900/3000 RPM	9.73	50	GCR10-14	150 HP	175HP	7.5 HP
			10	50	GCR10-16	150 HP	175HP	7.5 HP
			11	50	GCR10-16	200 HP	193HP	7.5 HP
			12	50	GCR10-18	200 HP	216HP	10 HP
			13	50	GCR10-20	200 HP	253HP	10 HP
			13.85	50	GCR10-20	250 HP	253HP	10 HP
1250(4732)	78-140 (5.3- 9.6)	FGHC 200-150-250 2900/3000 RPM	5.5	60	GCR 15-5	100 HP	115HP	5.5 HP
			6	60	GCR 15-5	100 HP	115HP	5.5 HP
			7	60	GCR 15-6	125 HP	145HP	7.5 HP
			8	60	GCR 15-7	150 HP	175HP	7.5 HP
1250(4732)	121-205 (8.34-14.13)	FGHC 150-125-315 2900/3000 RPM	9	60	GCR 15-8	150 HP	175HP	10 HP
			10	60	GCR 15-9	200 HP	216HP	10 HP
			11	60	GCR 15-9	200 HP	216HP	10 HP
			12	60	GCR 15-10	200 HP	275HP	15 HP
			13	60	GCR 15-12	250 HP	275HP	15 HP
1250(4732)	137-198 (9.45-13.72)	FGHC 200-150-300 2900/3000 RPM	9.45	60	GCR15-08	150 HP	175HP	10 HP
			10	60	GCR15-09	200 HP	193HP	10 HP
			11	60	GCR15-10	200 HP	216HP	15 HP
			12	60	GCR15-10	200 HP	253HP	15 HP
			13	60	GCR15-12	250 HP	253HP	15 HP
			13.72	60	GCR15-12	250 HP	275HP	15 HP
1500(5678)	75-139 (8.34-14.13)	FGHC 200-150-250 2900/3000 RPM	5.5	75	GCR 15-5	100 HP	115HP	5.5 HP
			6	75	GCR 15-6	125 HP	145HP	7.5 HP
			7	75	GCR 15-7	150 HP	175HP	7.5 HP
			8	75	GCR 15-8	200 HP	216HP	10 HP
			9	75	GCR 15-9	200 HP	216HP	10 HP

Horizontal Split Case Quick Selection guide

Rated Capacity in GPM / (LPM)	Pressure in PSI(Bar)	Electric & Diesel Engine Pump Model	Rated Pressure in Bar	Jockey Flow in USgpm	Jockey Pump Model	Electric Motor HP @ 2900 RPM	Diesel Engine HP @ 3000 RPM	Jockey Pump HP @ 2900 RPM
1500(5678)	113-210 (7.8-14.48)	FGHC 250-200-315 2900 RPM Motor Driven	10	75	GCR15-10	300HP	330HP	15HP
			11	75	GCR15-10	350HP	330HP	15HP
			12	75	GCR15-12	400HP	360HP	15HP
	135-203 (7.79-13.99)	FGHC 250-200-400 2350 RPM Engine Driven	13	75	GCR15-12	400HP	490HP	15HP
			13.99	75	GCR15-14	450HP	490HP	15HP
1500(5678)	184-245 (12.68-16.89)	FGHC 250-200-650 1470 RPM	15	75	GCR15-14	400HP	450HP	15HP
			16	75	GCR15-17	450HP	522HP	20HP
1500(5678)	130-194 (8.96-13.40)	FGHC 200-150-300 2900 RPM	8.96	75	GCR15-09	200HP	193HP	10HP
			9	75	GCR15-09	200HP	193HP	10HP
			10	75	GCR15-10	200HP	216HP	15HP
			11	75	GCR15-10	200HP	253HP	15HP
			12	75	GCR15-12	250HP	253HP	15HP
			13	75	GCR15-12	250HP	275HP	15HP
			13.40	75	GCR15-14	250HP	275HP	15HP
2000(7571)	80-133 (5.5-9.17)	FGHC 250-200-250 2900/3000 RPM	6	100	GCR 20-6	200 HP	217HP	10 HP
			7	100	GCR 20-7	200 HP	249HP	10 HP
	80-133 (5.5-9.17)	FGHC 250-200-250 2900 RPM Motor driven	8	100	GCR 20-8	250 HP	330HP	15 HP
	72-133 (4.96-9.17)	FGHC 250-200-315 2350 RPM Engine driven	9	100	GCR 20-10	300 HP	330HP	15 HP
2000(7571)	109-209 (7.5 - 14.41)	FGHC 250-200-315 2900 RPM Motor Driven	10	100	GCR20-10	350HP	330HP	15HP
			11	100	GCR20-12	350HP	360HP	20HP
	131-202 (9.0 - 13.92)	FGHC 250-200-400 2350 RPM Engine Driven	12	100	GCR20-12	400HP	490HP	20HP
			13	100	GCR20-12	450HP	490HP	20HP
2000(7571)	180-242 (12.41-16.68)	FGHC 250-200-650 1470 RPM Motor Driven	13.9	100	GCR20-14	450HP	490HP	20HP
	131-202 (9.0-13.92)	FGHC 250-200-400 2350 RPM Engine Driven						
	180-242 (12.41-16.68)	FGHC 250-200-650 1470 RPM	15	100	GCR20-14	450HP	522HP	20HP

Horizontal Split Case Quick Selection guide

Rated Capacity in GPM / (LPM)	Pressure in PSI(Bar)	Electric & Diesel Engine Pump Model	Rated Pressure in Bar	Jockey Flow in USgpm	Jockey Pump Model	Electric Motor HP @ 2900 RPM	Diesel Engine HP @ 3000 RPM	Jockey Pump HP @ 2900 RPM
2000(7571)	140-200 (9.66-13.79)	FGHC 250-200-300 2900/3000 RPM	9.66	75	GCR20-10	250HP	275HP	15HP
			10	75	GCR20-10	250HP	300HP	15HP
			11	75	GCR20-12	300HP	-	20HP
			12	75	GCR20-12	300HP	-	20HP
			13	75	GCR20-12	350HP	-	20HP
			13.79	75	GCR20-14	350HP	-	20HP
2500(9464)	93-152 (6.41-10.48)	FGHC 300-250-500 1470 RPM	6.5	125	GCR32-05-2	250HP	240HP	15HP
			7	125	GCR32-05-2	250HP	300HP	15HP
			8	125	GCR32-06-2	300HP	385HP	15HP
	93-152 (6.41-10.48)	FGHC 300-250-500 1470 RPM Motor Driven	9	125	GCR32-06	350HP	330HP	15HP
	126-199 (8.68-13.72)	FGHC 250-200-400 2350 RPM Engine Driven	10	125	GCR32-07-2	400HP	490HP	20HP
2500(9464)	152-224 (10.48 - 15.44)	FGHC 300-250-650 1470 RPM Motor Driven	11	125	GCR32-08-2	400HP	490HP	20HP
	126-199 (8.68 - 13.72)	FGHC 250-200-400 2350 RPM Engine Driven	12	125	GCR32-08	450HP	490HP	20HP
3000(11356)	90-151 (6.2-10.41)	FGHC 300-250-500 1470 RPM	6.5	150	GCR 32-05	250HP	300HP	15HP
			7	150	GCR 32-06-2	300HP	300HP	15HP
			8	150	GCR32-07-2	350HP	385HP	20HP
			9	150	GCR32-07	400HP	450HP	20HP
			10	150	GCR32-08	450HP	522HP	20HP

End Suction Quick Selection guide

Rated Capacity in GPM / (LPM)	Pressure in PSI(Bar)	Electric & Diesel Engine Pump Model	Rated Pressure in Bar	Jockey Flow in USgpm	Jockey Pump Model	Electric Motor HP @ 2900 RPM	Diesel Engine HP @ 3000 RPM	Jockey Pump HP @ 2900 RPM
50(189)	96-130 (6.61- 8.96)	FGBS 65-40-250	6.7	2.50	GCR 1s-15	15HP	15 HP	0.75 HP
			7	2.50	GCR 1s-15	15HP	15 HP	0.75 HP
			8	2.50	GCR 1s-17	15HP	15 HP	0.75 HP
			8.95	2.50	GCR 1s-19	15HP	20 HP	0.75 HP
	85-134 (5.86- 9.23)	FGBS 80-65-250	6	2.50	GCR 1s-13	15HP	15 HP	0.5 HP
			9.2	2.50	GCR 1s-19	20HP	30 HP	0.75 HP
100(378)	95-127 (6.55- 8.75)	FGBS 65-40-250	6.6	5.00	GCR 1-12	15HP	15 HP	1 HP
			7	5.00	GCR 1-13	15HP	20 HP	1 HP
			8	5.00	GCR 1-15	20 HP	20 HP	1 HP
			8.75	5.00	GCR 1-17	20 HP	30 HP	1.5 HP
	84-134 (5.79- 9.23)	FGBS 80-65-250	6	5.00	GCR 1-11	15HP	15 HP	0.75 HP
			9.2	5.00	GCR 1-17	25 HP	30 HP	1.5 HP
150(567)	83-135 (5.12- 9.30)	FGBS 80-65-250	6	7.50	GCR 1-13	15HP	20 HP	1 HP
			7	7.50	GCR 1-15	20 HP	30 HP	1 HP
			8	7.50	GCR 2-11	25 HP	30 HP	1.5 HP
			9	7.50	GCR 2-13	30HP	30 HP	2 HP
			9.3	7.50	GCR 2-13	30HP	57 HP	2 HP

End Suction Quick Selection guide

Rated Capacity in GPM / (LPM)	Pressure in PSI(Bar)	Electric & Diesel Engine Pump Model	Rated Pressure in Bar	Jockey Flow in USgpm	Jockey Pump Model	Electric Motor HP @ 2900 RPM	Diesel Engine HP @ 3000 RPM	Jockey Pump HP @ 2900 RPM
200 (757)	81-135 (5.58-9.30)	FGBS 80-65-250	5.8	10.00	GCR 3-11	20 HP	20 HP	1.5 HP
			6	10.00	GCR 3-11	20 HP	30 HP	1.5 HP
			7	10.00	GCR 3-13	25 HP	30 HP	1.5 HP
			8	10.00	GCR 3-15	30 HP	30 HP	1.5 HP
			9	10.00	GCR 3-17	30 HP	57 HP	2 HP
			9.3	10.00	GCR 3-17	40 HP	57 HP	2 HP
250(946)	78-134 (5.37-9.23)	FGBS 80-65-250	5.5	12.50	GCR 3-12	20 HP	30 HP	1.5 HP
			6	12.50	GCR 3-13	25 HP	30 HP	1.5 HP
			7	12.50	GCR 3-15	30 HP	30 HP	1.5 HP
			8	12.50	GCR 3-17	30 HP	57 HP	2 HP
			9	12.50	GCR 3-19	40 HP	57 HP	2 HP
300(1135)	94-132 (6.48-9.10)	FGBS 125-100-250	6.65	15.00	GCR 3-17	40 HP	57 HP	2 HP
			7	15.00	GCR 3-17	50 HP	57 HP	2 HP
			8	15.00	GCR 4-10	50 HP	57 HP	3 HP
			9	15.00	GCR 4-12	60 HP	71 HP	3 HP

End Suction Quick Selection guide

Rated Capacity in GPM / (LPM)	Pressure in PSI(Bar)	Electric & Diesel Engine Pump Model	Rated Pressure in Bar	Jockey Flow in USgpm	Jockey Pump Model	Electric Motor HP @ 2900 RPM	Diesel Engine HP @ 3000 RPM	Jockey Pump HP @ 2900 RPM
400(1514)	93-131 (6.41 - 9.03)	FGBS 125-100-250	6.55	20.00	GCR 4-10	50 HP	57 HP	3 HP
			7	20.00	GCR 4-10	50 HP	57 HP	3 HP
			8	20.00	GCR 4-12	60 HP	71 HP	3 HP
			9	20.00	GCR 4-12	75 HP	71 HP	3 HP
	122-207 (8.41 - 14.27)	FGBS 125-100-315	10	20.00	GCR 4-14	75 HP	83 HP	4 HP
			11	20.00	GCR 4-16	100 HP	115 HP	4 HP
			12	20.00	GCR 4-16	100 HP	115 HP	4 HP
			13	20.00	GCR 4-19	100 HP	115 HP	5.5 HP
			14	20.00	GCR 4-19	100 HP	115 HP	5.5 HP
	450(1703)	92-131 (6.34 - 9.03)	FGBS 125-100-250	6.5	22.50	GCR 4-10	50 HP	57 HP
7				22.50	GCR 4-10	50 HP	57 HP	3 HP
8				22.50	GCR 4-12	60 HP	71 HP	3 HP
9				22.50	GCR 4-14	75 HP	83 HP	4 HP
121-207 (8.34 - 14.27)		FGBS 125-100-315	10	22.50	GCR 4-14	75 HP	83 HP	4 HP
			11	22.50	GCR 4-16	100 HP	115 HP	4 HP
			12	22.50	GCR 4-19	100 HP	115 HP	5.5 HP
			13	22.50	GCR 4-19	100 HP	115 HP	5.5 HP
			14	22.50	GCR 4-22	125 HP	145 HP	5.5 HP

End Suction Quick Selection guide

Rated Capacity in GPM / (LPM)	Pressure in PSI(Bar)	Electric & Diesel Engine Pump Model	Rated Pressure in Bar	Jockey Flow in USgpm	Jockey Pump Model	Electric Motor HP @ 2900 RPM	Diesel Engine HP @ 3000 RPM	Jockey Pump HP @ 2900 RPM
500(1892)	91-130 (6.21 - 8.96)	FGBS 125-100-250	6.5	25.00	GCR 4-10	50 HP	57 HP	3 HP
			7	25.00	GCR 4-12	60 HP	71 HP	3 HP
			8	25.00	GCR 4-14	60 HP	71 HP	4 HP
			8.96	25.00	GCR 4-14	75 HP	83 HP	4 HP
	120-207 (8.27 - 14.27)	FGBS 125-100-315	10	22.00	GCR 10-10	100 HP	115 HP	5.5 HP
			11	25.00	GCR 10-12	100 HP	115 HP	5.5 HP
			12	25.00	GCR 10-14	100 HP	115 HP	7.5 HP
			13	25.00	GCR 10-14	125 HP	145 HP	7.5 HP
			14	22.00	GCR 10-14	125 HP	145 HP	7.5 HP
	750(2838)	86-125 (5.92 - 8.61)	FGBS 125-100-250	6	37.50	GCR 10-7	60 HP	71 HP
7				37.50	GCR 10-8	75 HP	83 HP	4 HP
8				37.50	GCR 10-10	100 HP	115 HP	5.5 HP
8.6				37.50	GCR 10-10	100 HP	115 HP	5.5 HP
114-203 (7.65 - 13.99)		FGBS 125-100-315	9	37.50	GCR 10-12	100 HP	115 HP	5.5 HP
			10	37.50	GCR 10-12	100 HP	115 HP	5.5 HP
			11	37.50	GCR 10-14	125 HP	145 HP	7.5 HP
			12	37.50	GCR 10-14	125 HP	145 HP	7.5 HP
			13	37.50	GCR 10-16	150 HP	175 HP	7.5 HP
			13.99	37.50	GCR 10-16	150 HP	175 HP	7.5 HP

End Suction Quick Selection guide

Rated Capacity in GPM / (LPM)	Pressure in PSI(Bar)	Electric & Diesel Engine Pump Model	Rated Pressure in Bar	Jockey Flow in USgpm	Jockey Pump Model	Electric Motor HP @ 2900 RPM	Diesel Engine HP @ 3000 RPM	Jockey Pump HP @ 2900 RPM
1000(3785)	104-188 (7.17 - 12.96)	FGBS 150-125-315	7.3	50.00	GCR 15-6	100 HP	115 HP	7.5 HP
			8	50.00	GCR 15-7	125 HP	145 HP	7.5 HP
			9	50.00	GCR 15-8	125 HP	145 HP	10 HP
			10	50.00	GCR 15-8	150 HP	175 HP	10 HP
			11	50.00	GCR 15-9	200 HP	216 HP	10 HP
			12	50.00	GCR 15-10	200 HP	216 HP	15 HP
			12.96	50.00	GCR 15-12	200HP	216 HP	15 HP



GENERAL PUMPS

GENERAL PUMPS, S.L.U.

Pol. Ind. El Oliveral (U.E.7, Nave nº1) - Calle W
46394 Ribarroja del Turia - Valencia Spain
Tel. : +34 96 1665200 / Fax :+34 96 1665052
E-mail: info@pumpsgp.com • www.pumpsgp.com

01.01.060124.0117